

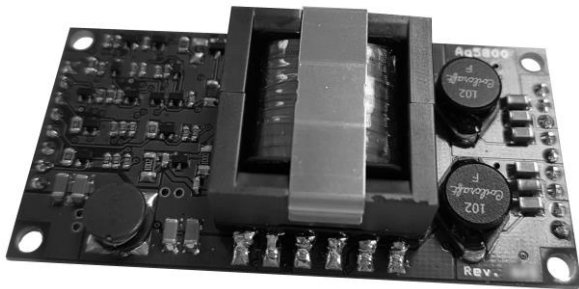

# Ag5800

IEEE802.3bt PD Module

## 1. Features



- Type 4 PD Compliant with IEEE802.3bt
- 85 Watt Output Power
- Compact DIL package - 70mm(L) x 35mm(W) x 17mm(H)
- High efficiency DC/DC converter
- 12V or 24V output with a wide adjustable output voltage range
- 1500V isolation (input to output)
- Input voltage range 36V to 57V
- Low output ripple and noise
- Complete PD solution with minimal (low cost) external components required
- Overload, thermal and short-circuit protection
- Silvertel "design-in" assistance

## 2. Description

The Ag5800 is an IEEE802.3bt Power over Ethernet module that can deliver up to 85 Watts\* of output power when connected to an IEEE802.3bt PSE. Suitable for applications such as PTZ IP cameras, LED lighting, door access systems, intelligent displays and sensors, monitors and projectors.

The module's input conforms to the IEEE 802.3bt standard for signature recognition and class programming. It has been designed to work with IEEE802.3bt and existing high power PSE's from leading manufacturers.

The high efficiency DC/DC converter operates over a wide input voltage range and provides a regulated low ripple and low noise output. The DC/DC converter also has built-in overload, thermal and short-circuit output protection.

\*See section 5.7- Output Power

## Table of Contents

1. Features .....	1
2. Description .....	1
Table of Contents.....	2
Table of Figures .....	2
3. Ag5800 Product Selector.....	4
4. Pin Description .....	5
5. Functional Description .....	6
5.1 Inputs .....	6
5.2 PD Signature.....	6
5.3 Isolation.....	7
5.4 Power Classification.....	7
5.5 Legacy Classification .....	7
5.6 Power Supply .....	8
5.7 Output Power .....	8
5.8 PSE Type Detection.....	9
5.9 High Power Applications .....	11
5.10 DC/DC Converter.....	12
5.11 Output Configuration .....	12
5.12 Output Adjustment .....	12
5.13 Output Power .....	13
5.14 Typical Connections.....	14
6. Operating Temperature Range.....	15
7. Protection .....	17
8. EMC.....	17
9. Electrical Characteristics .....	19
9.1 Absolute Maximum Ratings <sup>1</sup> .....	19
9.2 Recommended Operating Conditions .....	19
9.3 DC Electrical Characteristics.....	19
10. Package.....	21
10.1 Heat Sink Assembly .....	22
10.2 PCB Thermal Layout.....	23
10.3 Heatpad Footprint .....	24

## Table of Figures

Figure 1: Block Diagram .....	4
Figure 2: Ag5800 Package Format.....	4
Figure 3: Typical System Diagram.....	6
Figure 4: PoH Enable Connection .....	8
Figure 5: Available Output Power with an IEEE802.3bt PSE Connection .....	9
Figure 6: Physical Layer Detect Configuration.....	10
Figure 7: High Power configuration .....	11
Figure 8: Output Configurations.....	12
Figure 9: Output Adjustment.....	13
Figure 10: Typical Connection Diagram.....	14
Figure 11: Operating Temperature .....	15

Figure 12: Operating Temperature (Thermally connected to PCB and enclosure) ..... 16  
Figure 13: Operating Temperature (Thermally connected to PCB) ..... 16  
Figure 14: EMC Filtering..... 18  
Figure 15: Suggested Heat Sink Assembly ..... 22  
Figure 16: Suggested PCB Thermal Layout ..... 23  
Figure 17: Suggested Heatpad Footprint..... 24

### 3. Ag5800 Product Selector

Part Number†	Nominal Output Voltage ‡	Maximum Output Power *
Ag5800	12V / 24V	85W

\*Will operate up to 100W when used with a DC Power Supply at 25°C with adequate thermal management

† The Ag5800 fully meets the requirements of RoHS directive 2011/65/EC & EU RoHS 2, Moisture Sensitive Level 1 and HBM 1.

‡ Voltage depending on output configuration (Parallel or Series), see Section 5.11.

**Table 1: Ordering Information**

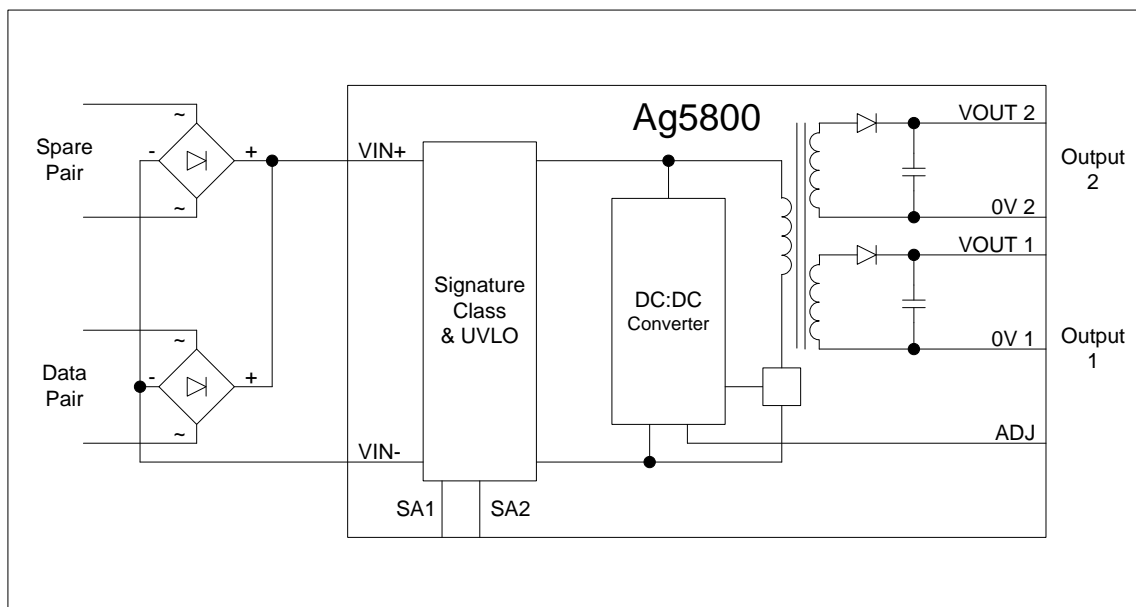

*Figure 1: Block Diagram*



*Figure 2: Ag5800 Package Format*

## 4. Pin Description

### Input Connector Pins

Pin #	Name	Description
1	SA1	Signature resistance adjustment (see section 5.2) - Default No connect
2	SA2	Signature resistance adjustment (see section 5.2) - Default No connect
3	AT-Det	<b>AT Detect Output.</b> This pin indicates if an IEEE802.3at PSE is supplying power to its inputs; see Section 5.4 for more details.
4	TYP3-Det	<b>TYPE 3 IEEE802.3bt Detect Output.</b> This pin indicates if a Type 3 IEEE802.3bt PSE is supplying power to both inputs; see Section 5.4 for more details.
5	TYP4-Det	<b>Type 4 IEEE802.3bt Detect Output.</b> This pin indicates if an IEEE802.3bt PSE is supplying power to both inputs; see Section 5.4 for more details.
6	PoH_En	<b>PoH_Enable Connection.</b> If the PD is connecting to an existing HDBaseT PoH or UPOE* system then this pin should be connected to VIN- to enable the PSE to provide full power.
7	VIN-	<b>Direct Input -.</b> This pin connects to the negative (-) output of the input bridge rectifier.
8	VIN+	<b>Direct Input +.</b> This pin connects to the positive (+) output of the input bridge rectifier.

\*When used with the Data Link Layer

### Output Connector Pins

Pin #	Name	Description
9&10	VOUT 2	<b>DC Output.</b> This pin provides the secondary output from the DC/DC converter.
11&12	0V 2	<b>Ground.</b> The ground return for the VOUT 2 output.
13&14	VOUT 1	<b>DC Output.</b> This pin provides the main regulated output from the DC/DC converter.
15&16	0V 1	<b>Ground.</b> The ground return for the VOUT 1 output.
17	ADJ	<b>Output Adjust.</b> The output voltage can be adjusted from its nominal value, by connecting an external resistor from this pin to either the VOUT 1 pin or the 0V 1 pin.

## 5. Functional Description

### 5.1 Inputs

The Ag5800 has a single input that can be connected to two external bridge rectifiers (see Figure 1: Block Diagram). The Ag5800 was developed to be powered with the Silvertel Ag6800 IEEE802.3bt PSE along with other leading manufactures IEEE802.3bt compliant PSEs. It can also be used with other high Power PSE's i.e. PoH PSE's and Pihong's legacy 12.5K signature PSEs with the setup explained in section 5.2 and 5.3.

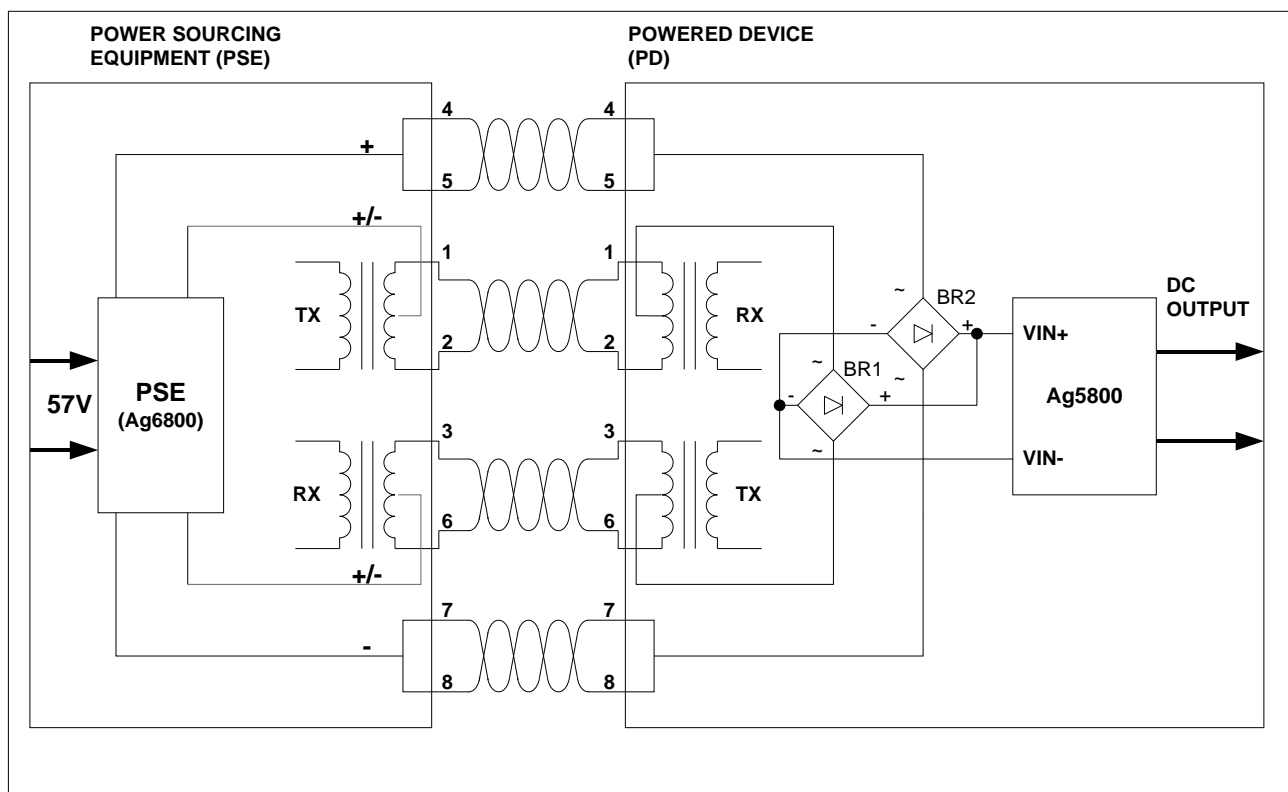

Figure 3: Typical System Diagram

### 5.2 PD Signature

The Ag5800 input complies with the IEEE802.3bt specification and provides signature and control circuitry to give full backwards PoE standards compatibility. When the inputs are connected to a Power Sourcing Equipment (PSE), they will automatically present a Powered Device (PD) signature to the PSE (when requested). The equipment will then recognise that a PD is connected to that line and supply power.

Note: The SA1 and SA2 pins must be connected together when used with a Pihong 12.5K signature resistance PSE i.e. POE80U/POE60U PSE. For all other PSE's these pins should be left unconnected.

### 5.3 Isolation

To meet the isolation requirements of IEEE802.3bt section 145.4.1 a Powered Device (PD) must pass the electrical strength test of IEC 60950 sub clause 6.2. This calls for either a) 1500VAC test or b) 2250V dc for 60s or c) 1500V impulse test. The Ag5800 has been designed to meet c) 1500V impulse test. When mounting the module to the heat sink, you must ensure a clearance of 1.5mm minimum between the pins of the connectors and the heat sink or use some form of isolation such as at least two layers of 3M#56 insulating tape.

### 5.4 Power Classification

The Ag5800 is Type 4 - Class 8 PD requesting the highest nominal amount of power from an IEEE802.3bt PSE by displaying the correct class pulses shown in Table 2 below. If the Ag5800 is connected to an IEEE802.3at PSE, the PSE will recognise the initial Class 4 pulse from the Ag5800 as a Type 2 PD and provide ~25W.

<u>PD Type</u>	<u>Requested Class</u>	<u>Class Pulse A</u>	<u>Class Pulse B</u>	<u>Minimum Requested Power (W)</u>
3	1	1	1	3.84
	2	2	2	6.49
	3	3	3	13
	4	4	4	25.5
	5	4	0	40
	6	4	1	51
4	7	4	2	62
	8	4	3	71.3

**Table 2: Classification Table**

### 5.5 Legacy Classification

If the Ag5800 is connected to a PoH PSE and the user still requires the full amount of power then the user can connect Pin 6 (PoH\_En) to Pin 7 (VIN-) providing the correct classification and achieving full power draw- See Figure 4.

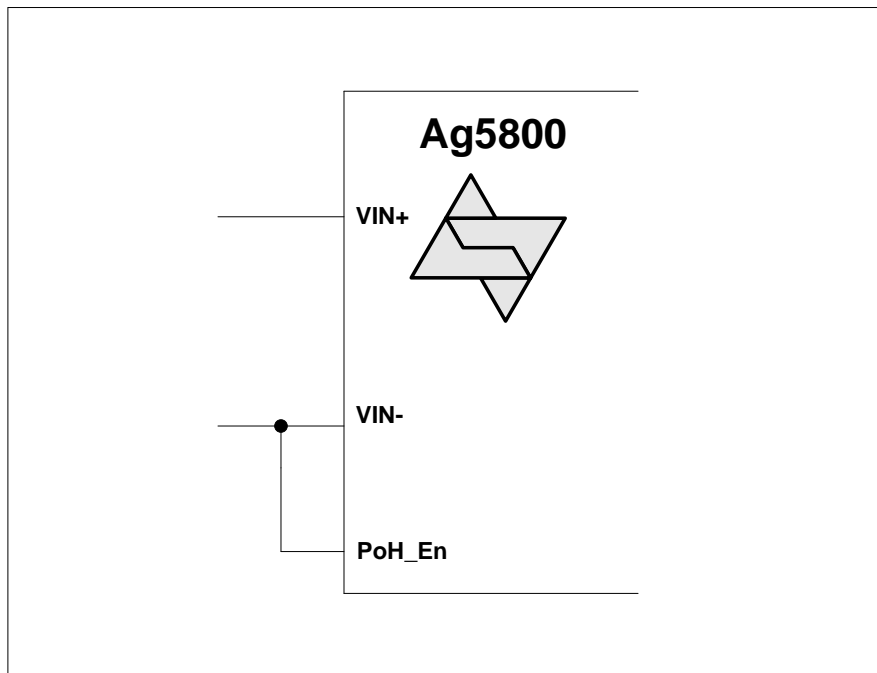

*Figure 4: PoH Enable Connection*

## 5.6 Power Supply

The Ag5800 is a Class 8 Type 4 IEEE802.3bt Power Device and as such should be powered with the appropriate power supply, this being either an IEEE802.3bt compliant PSE or a DC power supply with a minimum power specification of 52V at 3A. This minimum rating power supply must be chosen regardless of the customers load as the inrush and power limits of the Ag5800 are designed to provide >85W out. If the customer is designing their own PSE to use with the Ag5800 they must also ensure that the power supply to the PSE is capable of this minimum power capability.

## 5.7 Output Power

The output power of the Ag5800 is limited by the available power at the input pins of the module. An IEEE802.3bt PSE can only provide a maximum of 99W from its output, however with connector, cable and diode bridge losses the available power at the input pins of the Ag5800 can vary considerably.

The graph shown in Figure 5 shows the maximum power output of the Ag5800 when connected to SilverTel's Ag6800 IEEE802.3bt PSE and also the losses using different category cables.



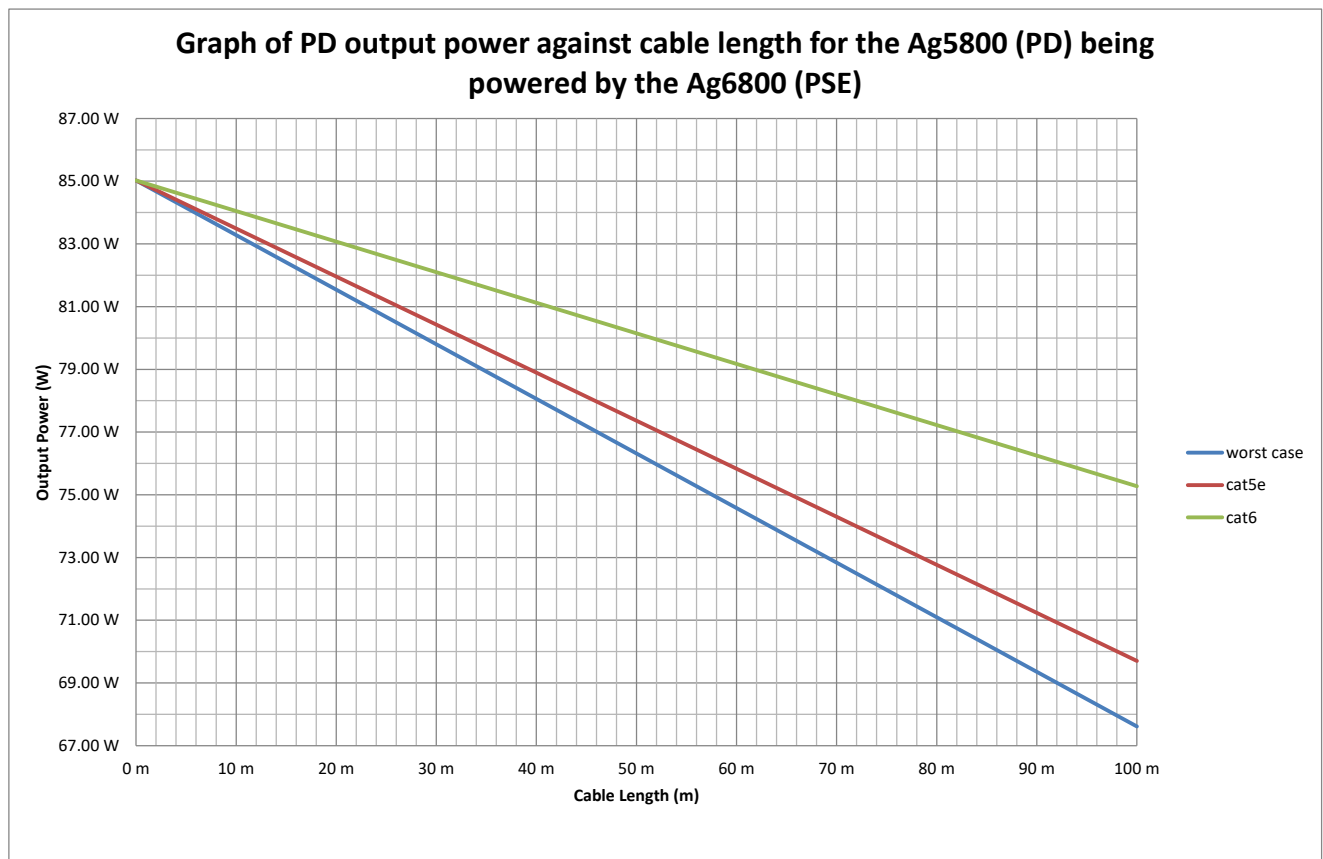

Note: This was calculated using typical cable resistances and with schottky bridge rectifiers part number: SS36 (Vf of 0.5V at the operating current) - Ag6800 supply voltage of 55V.

*Figure 5: Available Output Power with an IEEE802.3bt PSE Connection*

## 5.8 PSE Type Detection

The Ag5800 has three output pins which are used to identify the Type of PSE connected to its input such that communication can be sent over the Physical Layer as described in the IEEE802.3bt specification. Each output pin can be connected directly to an opto-coupler such that the output can cross the isolation barrier, as shown in Figure 6.

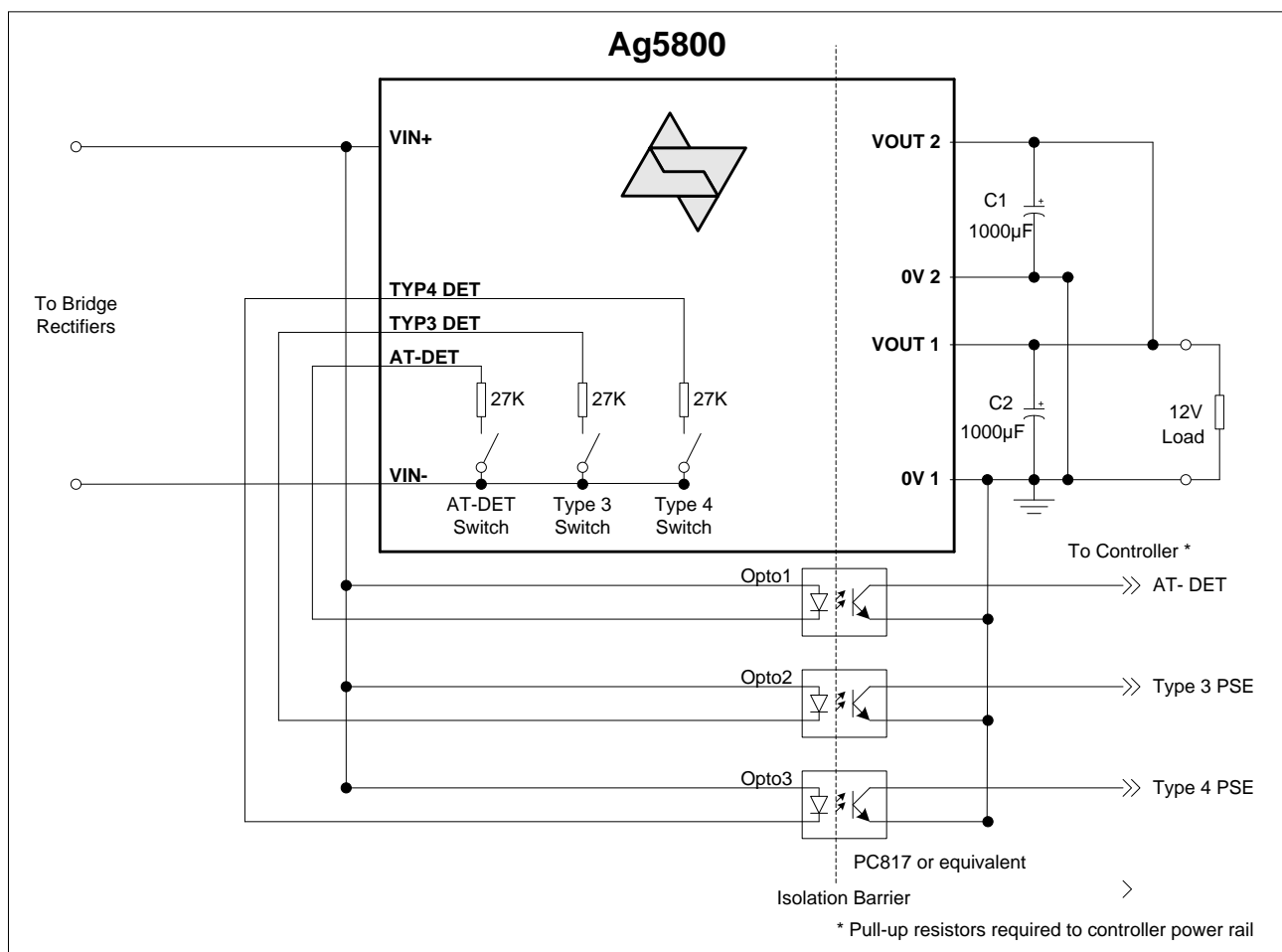

Figure 6: Physical Layer Detect Configuration

If an IEEE802.3af PSE is connected, the Ag5800 will power up but none of the detect outputs will be active.

If a standard IEEE802.3at PSE is connected, the AT-DET pin will be active and Opto1 will turn ON.

If a Type 3 IEEE802.3bt PSE is connected, the TYP3-DET pin will be active and Opto2 will turn ON.

If a Type 4 IEEE802.3bt PSE is connected, the TYP4-DET pin will be active and Opto3 will turn ON.

It is important to remember that Ag5800's output is limited to the capability of the PSE.

*Please Note: If the connected PSE does not support the Data Link Layer (DLL) Opto 1 to 3 do not need to be fitted and the Ag5800 will still draw the maximum power available from the PSE.*

## 5.9 High Power Applications

Figures 7a and 7b show typical application diagrams for the Ag5800 connected to the Ag6800 PSE.

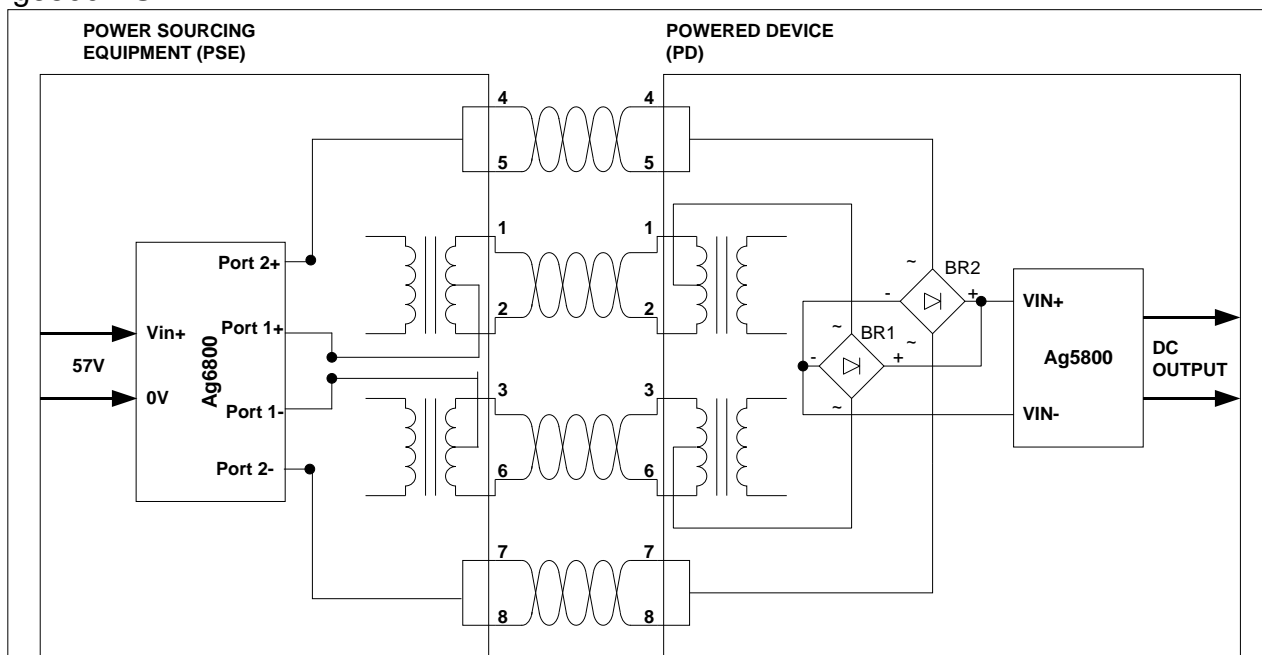

Figure 7a – Typical Application Diagram for Ag5800 using 10/100BASE-T

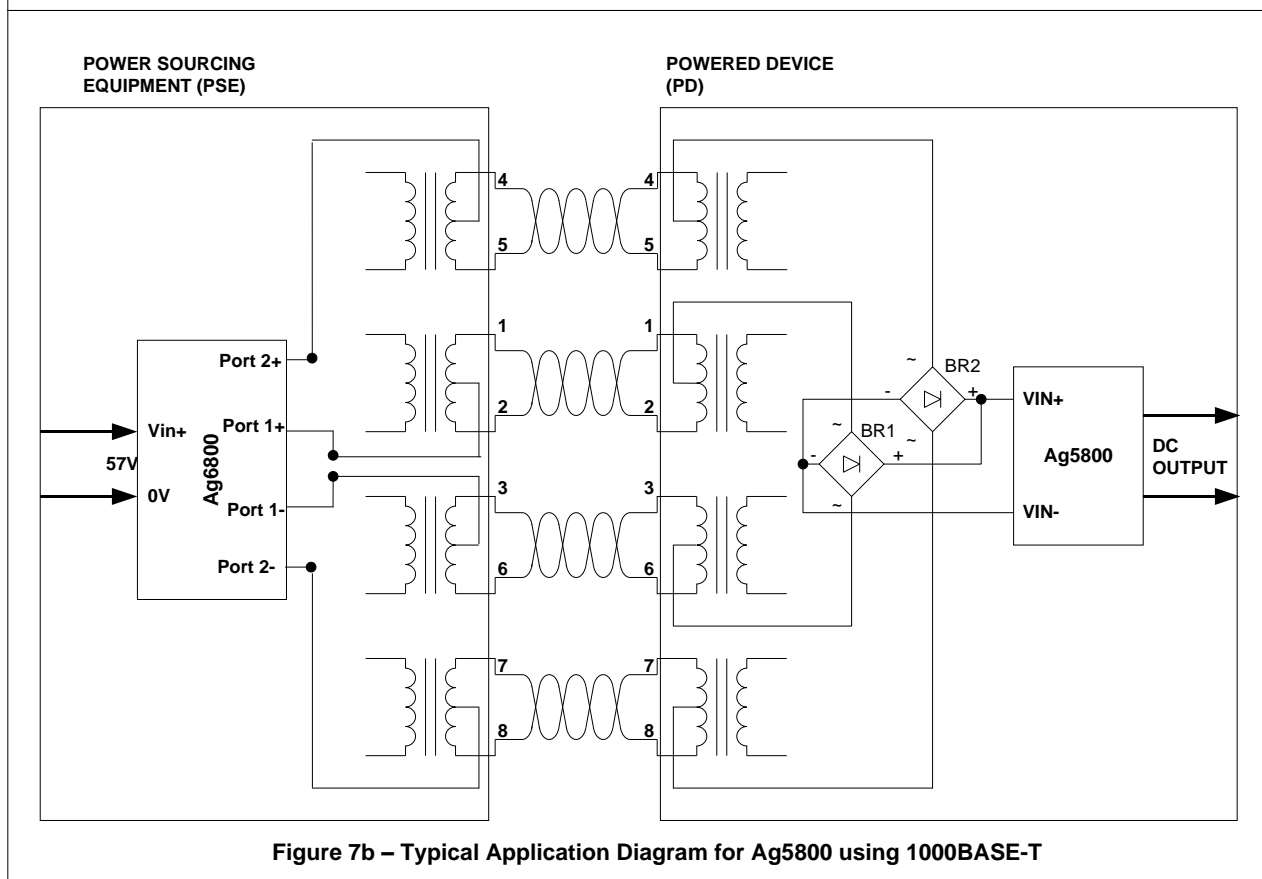

Figure 7b – Typical Application Diagram for Ag5800 using 1000BASE-T

Figure 7: High Power configuration

## 5.10 DC/DC Converter

The Ag5800's DC/DC converter provides a regulated low ripple and low noise output that has built-in output over-load and short-circuit protection.

## 5.11 Output Configuration

The Ag5800 has two outputs which must be connected either in parallel to provide 12V or in series to provide 24V, as shown in Figure 7: Output Configurations.

Output 2 voltage (VOUT 2) tracks the output 1 voltage (VOUT 1). The use of the two outputs separately is not recommended due to voltage regulation issues.

It is important that C1 and C2 are both used and connected as close to the output pins of the Ag5800 as possible (for both configurations).

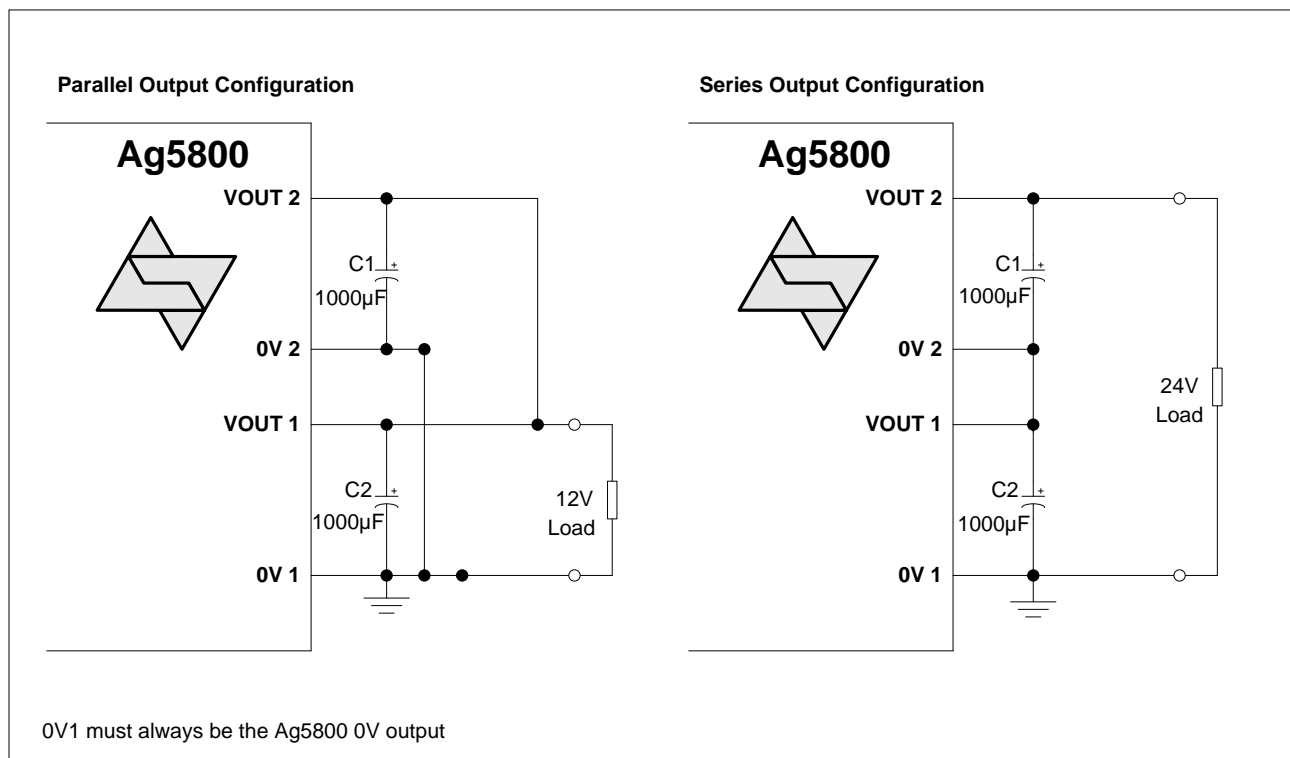
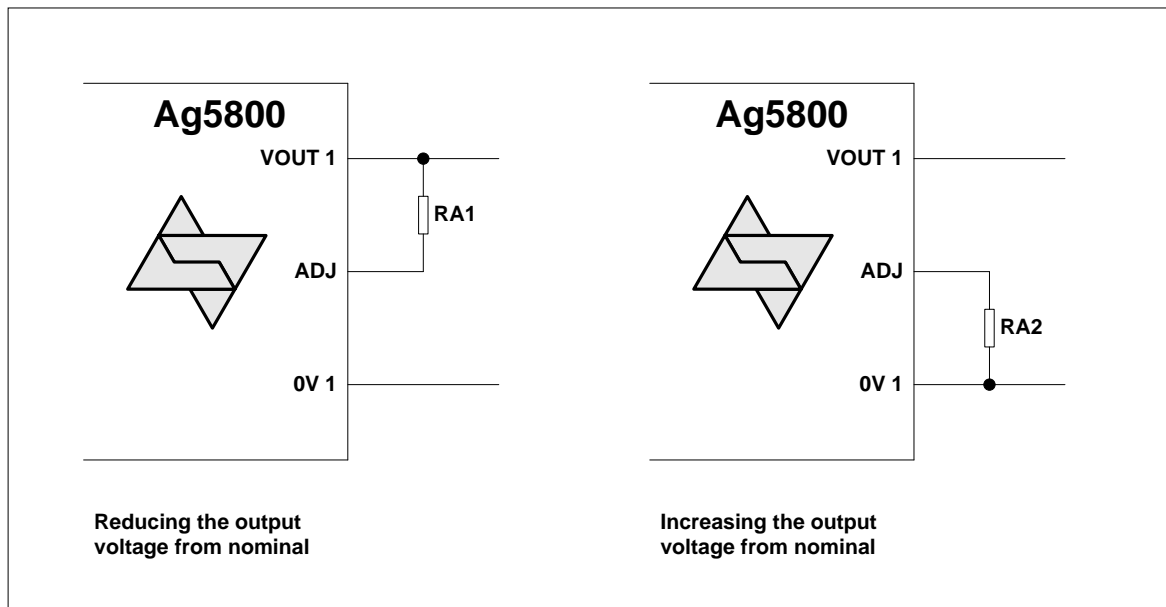

Figure 8: Output Configurations

## 5.12 Output Adjustment

The Ag5800 has an ADJ pin, which allows the output voltage to be increased or decreased from its nominal value.

The adjustment range allows the Ag5800 to provide an output voltage from 10.5V up to 30.2V. Voltage must not be adjusted to less than 10.5V or permanent damage may be caused. Contact Silvertel for further details.



*Figure 9: Output Adjustment*

<b>Reducing the output voltage, connect R between ADJ and VOUT 1</b>		
Value of RA1	VOUT Parallel	VOUT Series
Open Circuit	12V	24V
91K *	10.5V	21.V
<b>Increasing the output voltage, connect R between ADJ and 0V 1</b>		
Value of RA2	VOUT Parallel	VOUT Series
Open Circuit	12V	24V
8K2	15V	30.2V

**Table 3: Output Adjustment Resistor (R) Value**

\* RA1 must not be less than 91K. Adjusting Vout to less than 10.5V may cause permanent damage

*Note: When used with a DC supply the output load current must be reduced to keep the maximum power output at 100W or below.*

### 5.13 Output Power

The maximum output power of the Ag5800 is 100W\* when used with a DC supply; however this is limited by the available input power to the module. If used with an IEEE802.3bt PSE then the maximum achievable output power is 85W due to the available power the PSE can provide. (See section 5.7)

When calculating the output power, the following factors must be taken into account: -

1. Ag5800 efficiency
2. PSE output power
3. Cable and connector losses
4. Input bridge rectifier losses

\* When the output voltage is adjusted to its maximum the power must be limited to 100W. e.g. with  $V_{out}$  set to 30V the output current must be reduced to 3.4A.

### 5.14 Typical Connections

As shown in Figure 10: Typical Connection Diagram, a minimum of 1000 $\mu$ F must be connected across each output, positioned as close to the output pins as possible. These capacitors are needed for output filtering and step load change performance and can be a standard low cost electrolytic; they do not need to be a low ESR type.

The Signature and the Output Adjust inputs are optional and are provided to give greater flexibility to the Ag5800. Further information on using these inputs can be found in sections 5.4 Power Classification and 5.12 Output Adjustment.

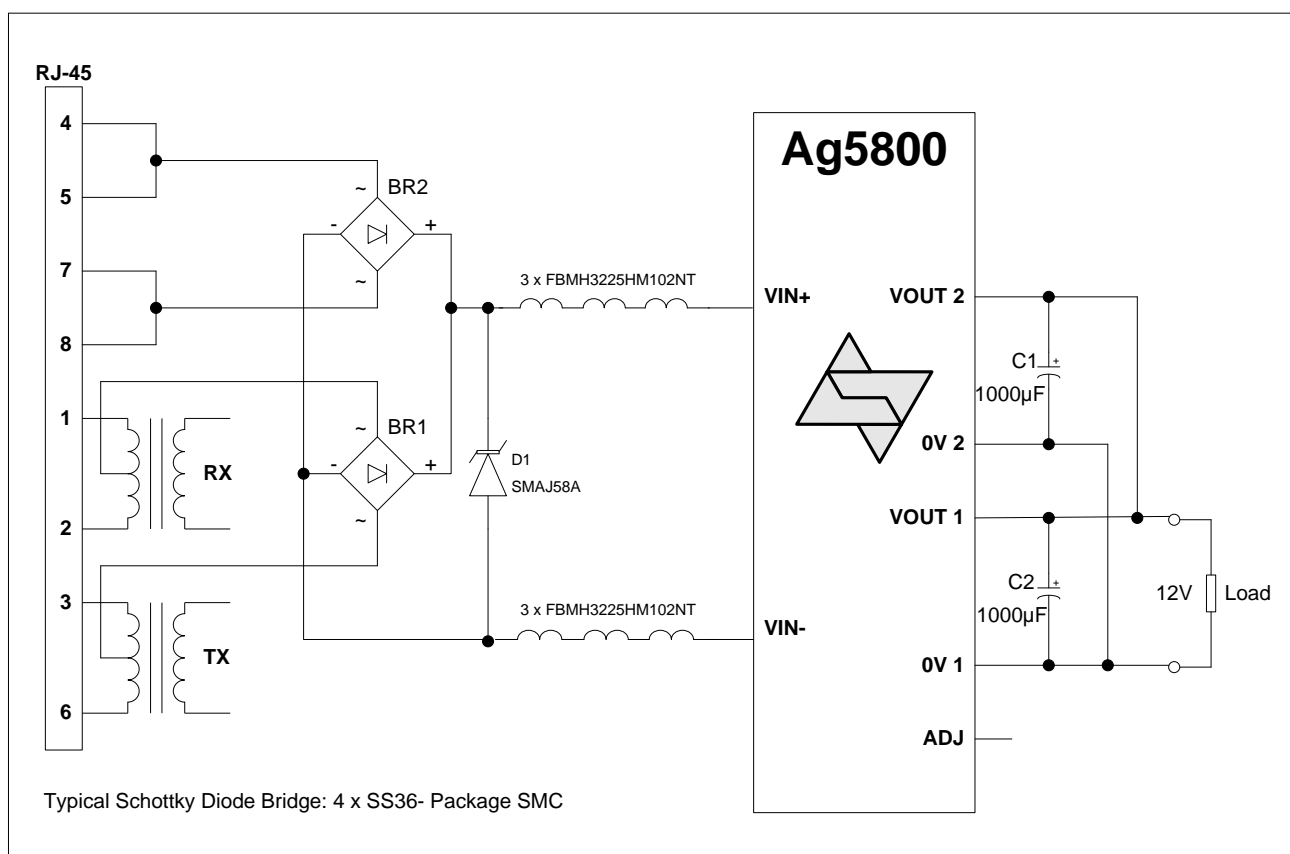

Figure 10: Typical Connection Diagram

## 6. Operating Temperature Range

It is important to remember that Ag5800 is a power supply, and as such careful consideration should be taken over the mechanical design of the host product, with provision for heat sinking and/or forced air cooling.

The Ag5800 will generate heat and has been designed to be soldered into the customers PCB which thermally connects the Ag5800 through the use of thermal pad or thermal paste such as Thermally conductive Oxime Cure paste. The customers PCB can then be thermally mounted (using a Bergquist .01" Ultra soft gap pad) to the chassis of the host equipment. Further thermal relief can be in the form of cooled or forced air improving the power output

Because each application is different it is impossible to give fixed and absolute thermal recommendations. However to obtain maximum power it is important that any enclosure used has sufficient ventilation and airflow over the Ag5800.

Figure 11 shows the maximum ambient temperature under continuous load conditions. The Ag5800 is capable of handling 85W up to 70°C with continuous airflow while thermally heatsinked to the customers PCB and enclosure. A suggested mounting method is shown in Figure 15.

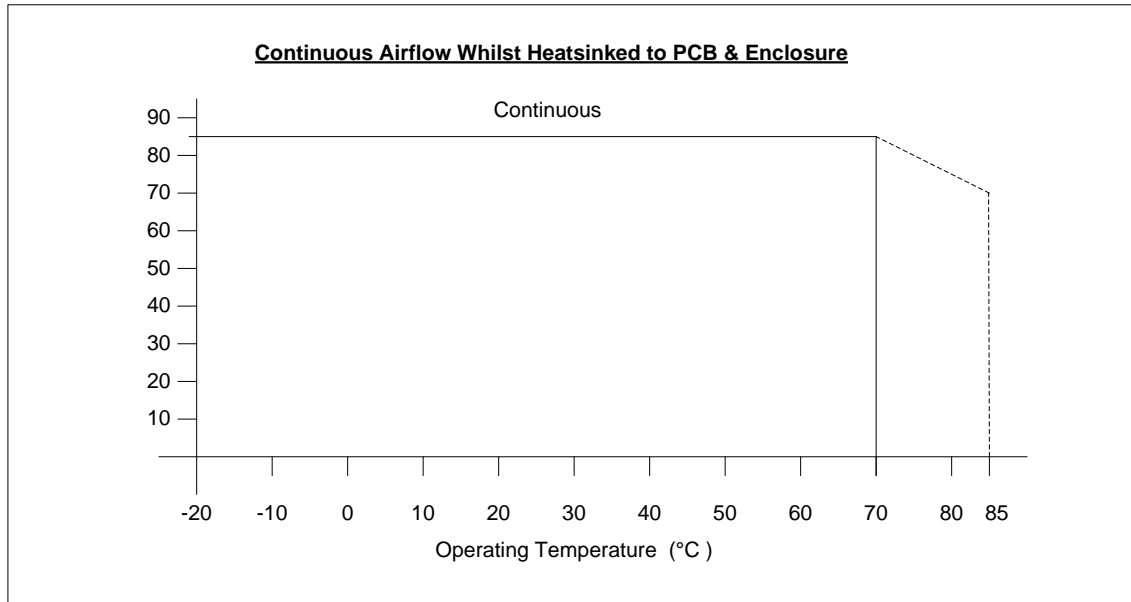

*Figure 11: Operating Temperature*

If the Ag5800 is thermally connected to the PCB and the customers' enclosure, then 85W can only be obtained up to 60°C as shown in Figure 12.

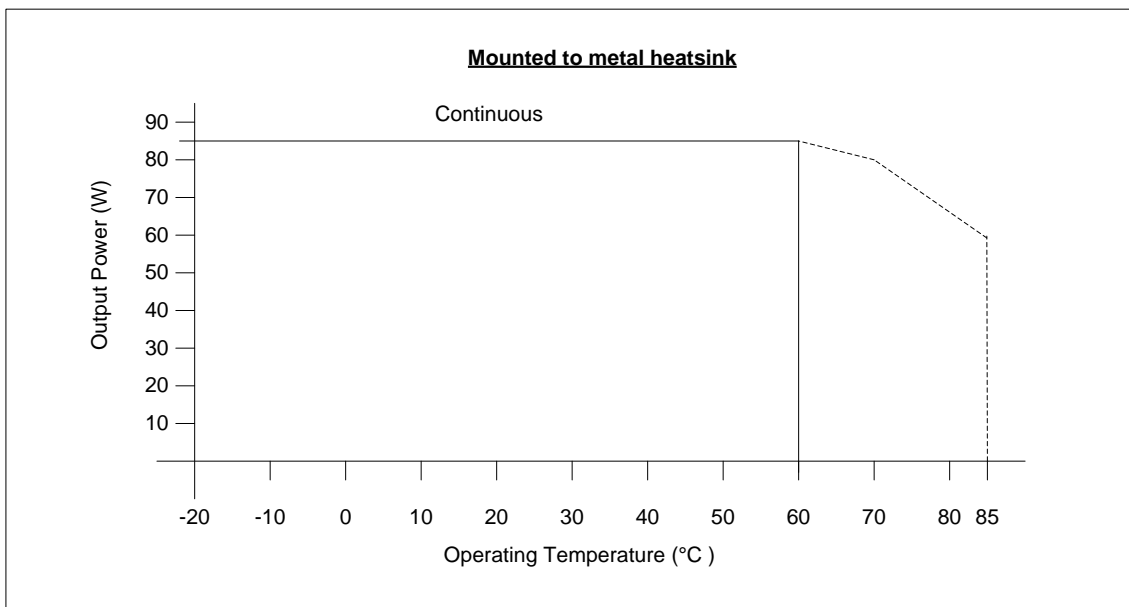

Figure 12: Operating Temperature (Thermally connected to PCB and enclosure)

If the Ag5800 is thermally connected to the PCB only, then 85W can only be obtained up to 50°C as shown in Figure 13.

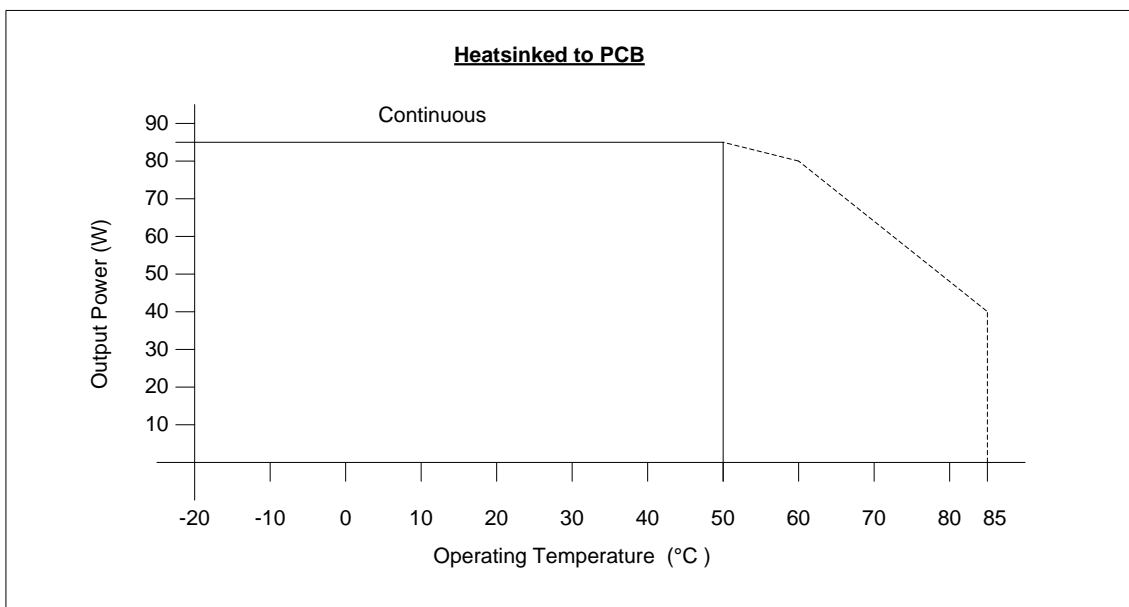

Figure 13: Operating Temperature (Thermally connected to PCB)

Suggested layout and dimensions of the thermal relief pads can be found in Figure 15 and Figure 16 respectively.



The Operating Temperature vs Power Output can be summarised as shown in Table 4 below:

Temperature	Heatsink Type- Ag5800 to:		
	PCB	PCB & Enclosure	PCB & Enclosure & Air Flow
30°C	85W	85W	85W
40°C	85W	85W	85W
50°C	85W	85W	85W
60°C	80W	85W	85W
70°C	70W	80W	85W
85°C	40W	60W	70W

**Table 4: Operating Temperature vs Power Output**

When intended for use in ambient temperatures below 0°C we would recommend a low ESR electrolytic capacitor be used on the DC output. Capacitors rated for -55°C operation should be used below 0°C.

## 7. Protection

The Ag5800 must be protected from over-voltages exceeding the 80V maximum rated surge input voltage. An inexpensive but effective solution can be achieved by connecting a Tranzorb diode across the input; see Apps Note “ANX-POE-Protection”.

## 8. EMC

The Ag5800 has been designed to pass EN55032 Class B, however the Ag5800 will only be one component within a system so we would always advise that provisions are put in place in case further noise reductions are needed. From our extensive experience we would recommend an inexpensive but effective solution to reduce emissions shown in Figure 14.

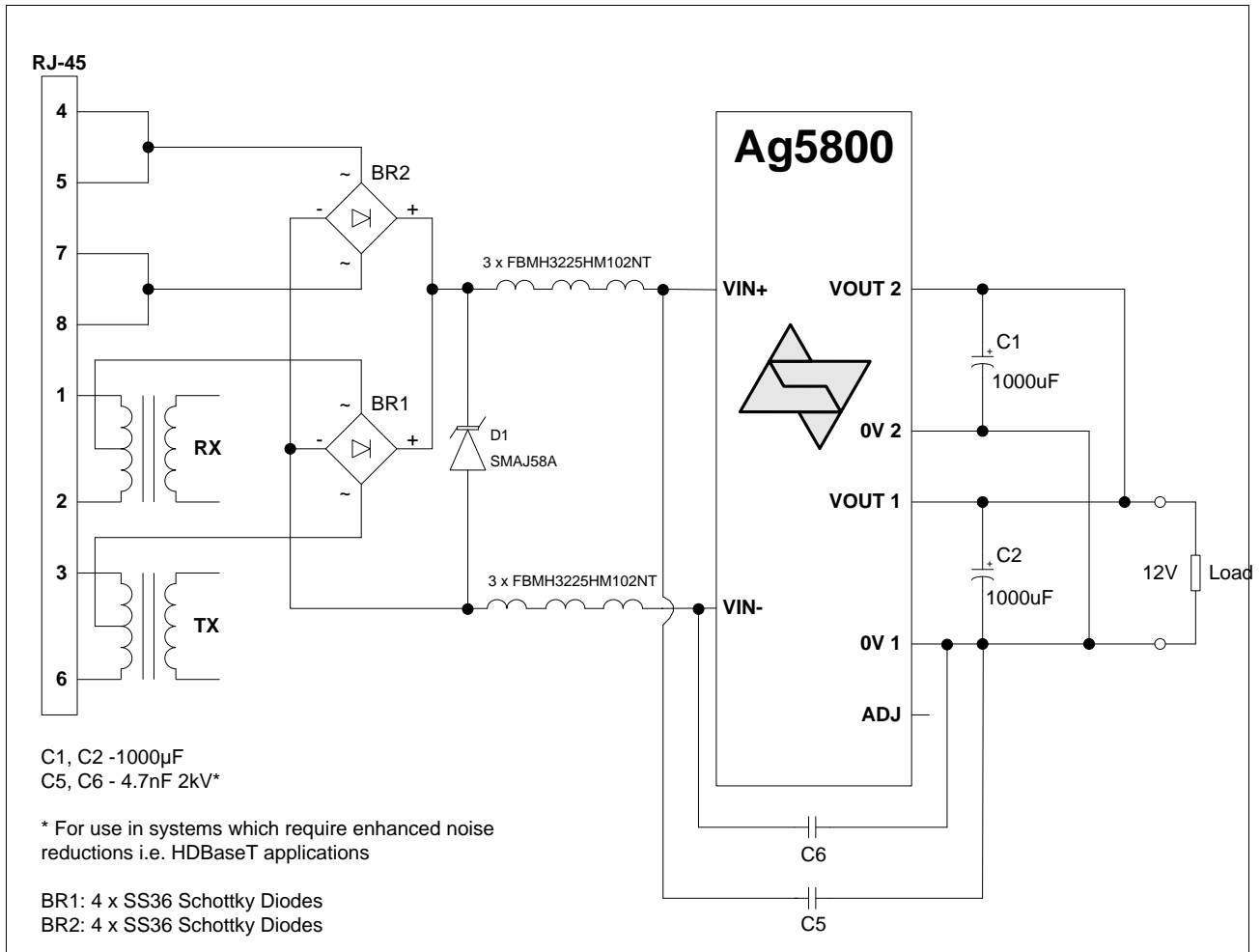

Figure 14: EMC Filtering

## 9. Electrical Characteristics

### 9.1 Absolute Maximum Ratings<sup>1</sup>

	Parameter	Symbol	Min	Max	Units
1	DC Supply Voltage	$V_{CC}$	-0.3	60	V
2	DC Supply Voltage Surge for 1ms	$V_{SURGE}$	-0.6	80	V
3	Storage Temperature	$T_S$	-40	+100	°C

Note 1: Exceeding the above ratings may cause permanent damage to the product. Functional operation under these conditions is not implied. Maximum ratings assume free airflow.

### 9.2 Recommended Operating Conditions

	Parameter	Symbol	Min	Typ	Max	Units
1	Input Supply Voltage <sup>1</sup>	$V_{IN}$	36	52	57	V
2	Under Voltage Lockout	$V_{LOCK}$	30		36	V
3	Operating Temperature <sup>2</sup>	$T_{OP}$	-40	25	85	$T_a$ / °C

Note 1: Output power limited by PSE current limit and supply voltage.

Note 2: See Section 6- Operating temperature range.

### 9.3 DC Electrical Characteristics

	DC Characteristic	Sym	Min	Typ <sup>1</sup>	Max	Units	Test Comments
1	Nominal Output Voltage	+VDC	11.4 22.8	12 24	12.6 25.2	V V	Parallel O/P Series O/P
2	Voltage Adjust Range	$V_{ADJ}$	10.5		30.2	V	See 5.12 Output Adjustment
3	Continuous Output Current <sup>2</sup> $V_{IN} = 52V$ Min, $V_{out} = 24V$ max	$I_{CONT}$			7.1 3.6	A A	Parallel O/P Series O/P
4	Line Regulation	$V_{LINE}$		0.1		%	@ 50W Load
5	Load Regulation	$V_{LOAD}$		0.1		%	@ $V_{IN}=52V$
6	Output Ripple and Noise Parallel O/P (12v) Series O/P (24v)	$V_{RN}$		26 41		mVp-p mVp-p	@ Max load
7	Minimum Load <sup>3</sup>	$I_{MIN}$	0			mA	
8	Short-Circuit Duration	$T_{SC}$			$\infty$	sec	
9	Efficiency	Eff		89		%	$V_{in} = 52V$ @4A Load
10	Isolation Voltage (I/O)	$V_{ISO}$			1500	$V_{PK}$	Impulse Test

Note 1: Typical figures are at 25°C with a nominal 57V supply, parallel output configuration (unless otherwise stated) and are for design aid only. Not Guaranteed

2: The output can operate up to 100W with a DC Supply but must not exceed 100W or 8.4A Parallel / 4.2A Series.

3: The Ag5800 has been designed to work normally when no load is connected, however a small load maybe required in order to keep the PSE on during its MPS check.

## 10. Package

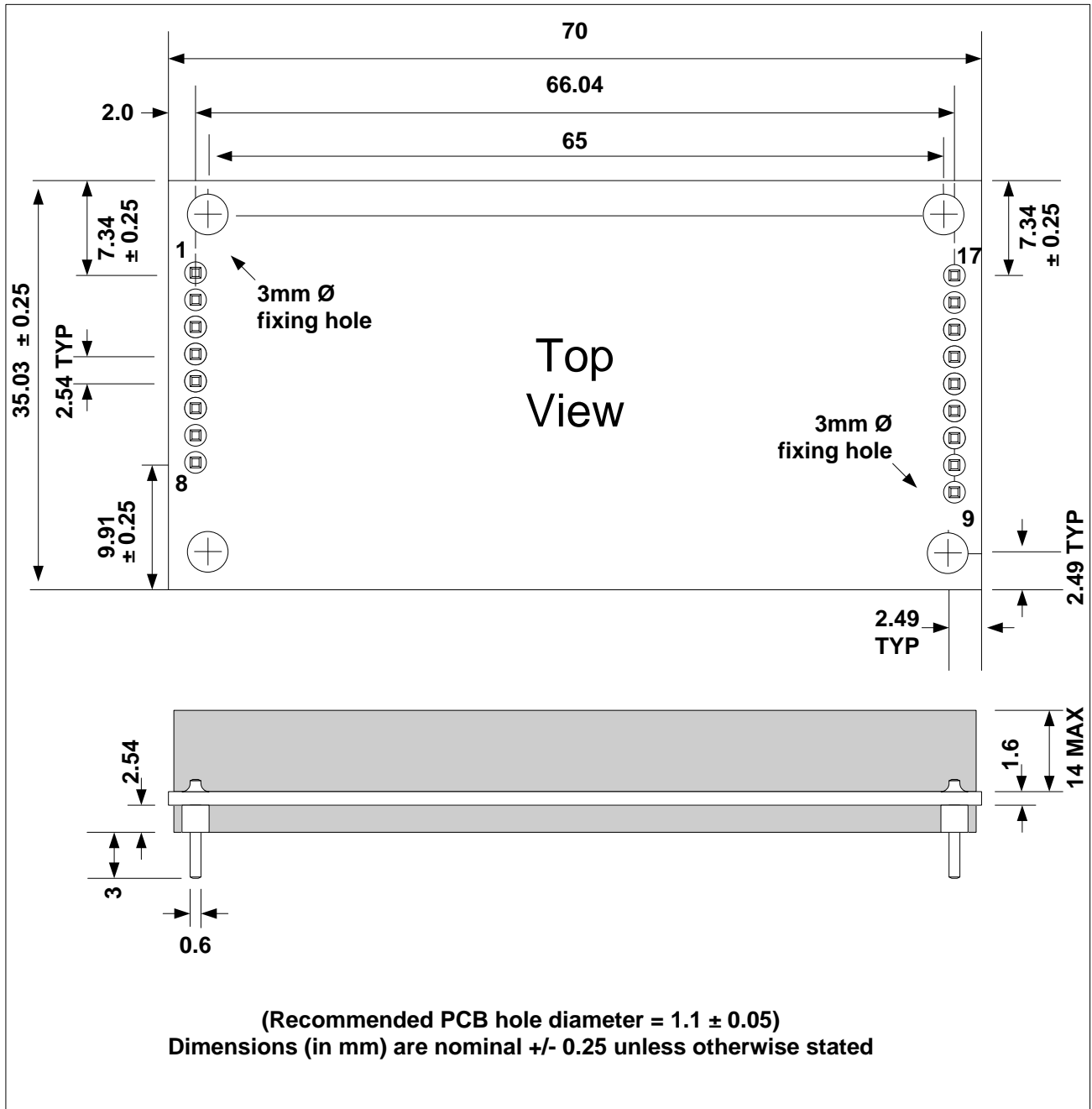

## 10.1 Heat Sink Assembly

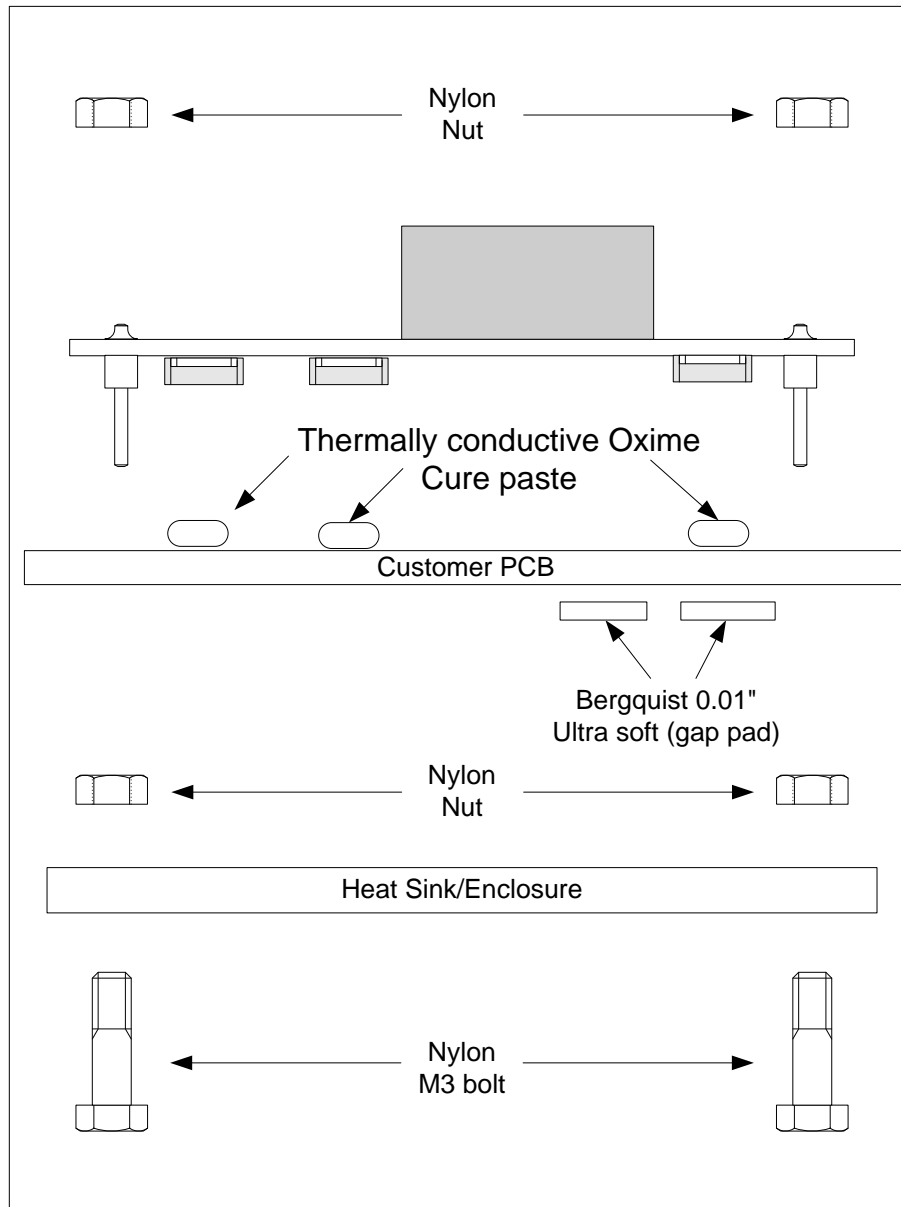

*Figure 15: Suggested Heat Sink Assembly*

## 10.2 PCB Thermal Layout

To attain continuous 85W operation the Ag5800 must be thermally connected to the customers PCB and their enclosure or heatsink. The thermal layout should have copper pads with a via array to help draw the heat through the PCB to the heatsink. An example of a thermal layout can be found below in Figure 16 with dimensions shown in Figure 17.

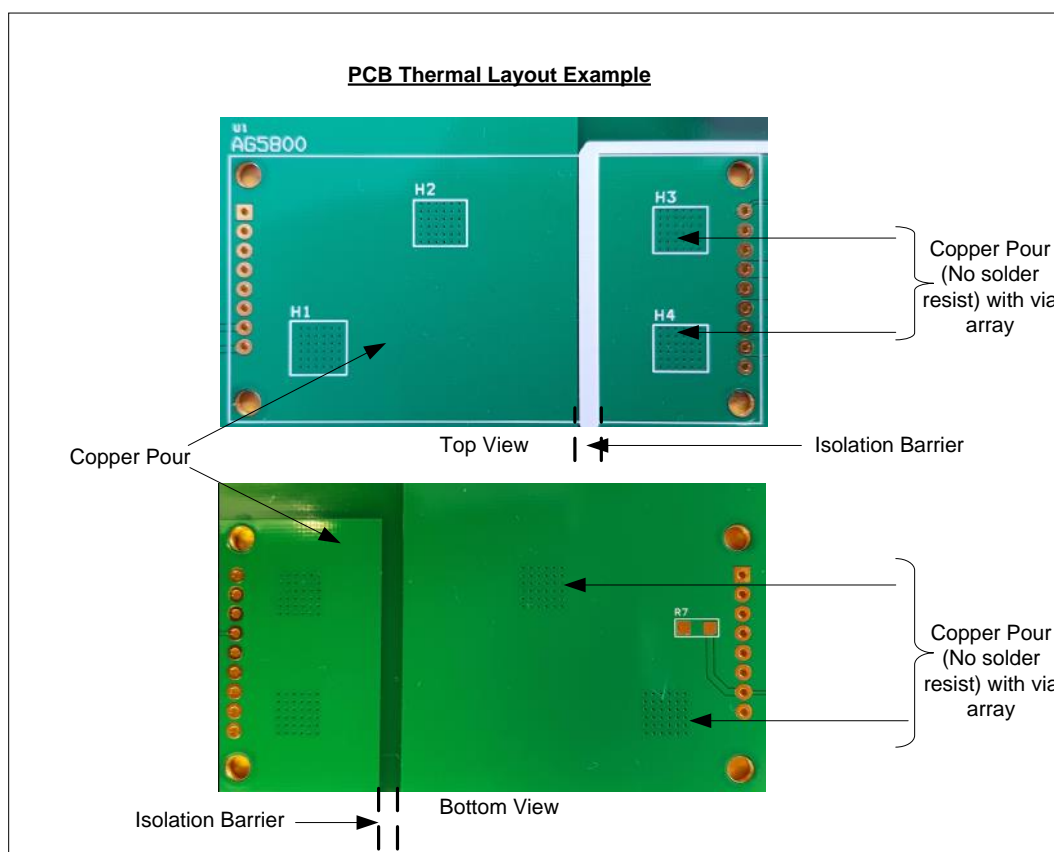

Figure 16: Suggested PCB Thermal Layout

### 10.3 Heatpad Footprint

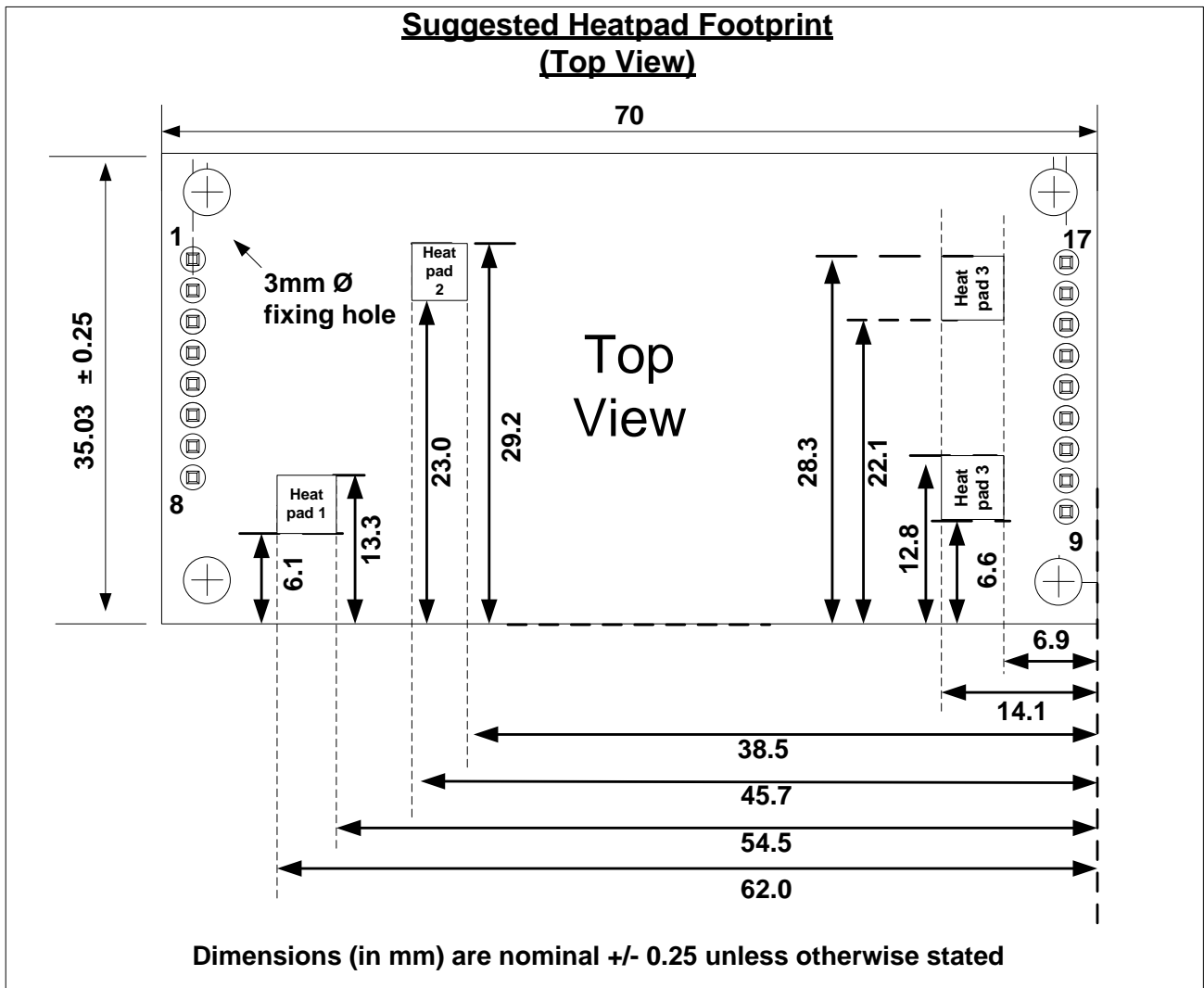

Figure 17: Suggested Heatpad Footprint

The latest revision of all application notes referenced in this document can be found on the Silver Telecom website “[www.silvertel.com](http://www.silvertel.com)”.

Information published in this datasheet is believed to be correct and accurate. Silver Telecom assumes no liability for errors which may occur or for liability otherwise arising out of use of this information or infringement of patents which may occur as a result of such use. No license is granted by this document under patents owned by Silver Telecom or licensed from third parties by Silver Telecom. The products, their specification and information appearing in this document are subject to change by Silver Telecom without notice.